

Dynamic shear properties of polysulphide and ethylene propylene rubbers over a wide range of frequency and temperature

M. N. DARROUJ

Assad Academy of Engineering, Ramousa, Aleppo, Syria

R. G. FAULKNER

Institute of Polymer Technology and Materials Engineering, University of Technology, Loughborough, Leicestershire LE11 3TU, UK

Methods for measuring dynamic shear properties of viscoelastic solids are discussed and a new method for direct measurement at high frequencies (1500 Hz) is outlined. The variation of complex shear modulus, dynamic in-phase shear modulus and the loss, out-of-phase shear modulus for polysulphide and ethylene propylene rubbers is shown as a function of temperature (-40 to 100°C) and frequency (50 to 1500 Hz). The Mooney theory of deformation of cross-linked polymer networks is used to define the molecular structure of the elastomers more fully. Recommendations are made for producing high-damping elastomers in the audio-frequency range.

1. Introduction

In recent years, there has been a growing interest in evaluating the dynamic mechanical properties of rubber-like materials for many engineering purposes. For damping noise and vibrations in structural components, the dynamic mechanical properties of elastomers are of great importance. These properties are highly dependent on frequency and temperature. Experimental data on these properties are, so far, limited to the low-frequency range (< 1000 Hz). It is true that indirect data produced by superposition (the method of reduced variables) are available over a wide range of frequency and temperature. The work reported in this paper involves a direct measurement of the dynamic shear properties of polysulphide rubber and ethylene propylene rubber over a wide range of frequency (50 to 1500 Hz) and over a wide range of temperature (-40 to 100°C) [1, 2]. The effect of curing time for polysulphide rubber is examined. The effect of strain amplitude is also examined. Comparison between the measured results and results produced by the indirect superposition method is also reported. Reasonable correlation between the results and the theory of rubber elasticity is described.

2. Calculations of dynamic shear properties

Details of the experimental arrangement used may be found in [2]. Properties are determined using a non-resonant forced vibration method. The mechanical arrangement of the vibrating specimen shown in Fig. 1 can be represented by a single degree of freedom system with viscous damping excited by a harmonic force, $F = F_0 \sin \omega t$, as shown in Fig. 2. The differential equation of motion of the system is found

from the free-body diagram to be

$$M\ddot{x} + C\dot{x} + Kx = F_0 \sin \omega t \quad (1)$$

where ω is the angular frequency, t is the time, M is the vibrating mass, C is the damping coefficient, K is the stiffness (spring rate), and x is the displacement. The solution to this equation consists of two parts: the complementary function, which is the solution of the homogeneous equation, and the particular integral. The complementary function, in this case, is damped free vibration, i.e. it is the solution of Equation 1 when its right-hand side is zero.

The particular integral (solution) to the above equation is a steady-state vibration of the same frequency, ω , as the excitation force. The particular solution can be assumed to be of the form

$$x = X \sin(\omega t - \phi) \quad (2)$$

where X is the amplitude of vibration, and ϕ is the phase of displacement with respect to the exciting force.

The amplitude and phase in the above equation are found by substituting Equation 2 into the differential Equation 1, remembering that in harmonic motions, the phases of velocity and acceleration are ahead of displacement by 90° and 180° , respectively. Considering the vibrator as the reference motion, the terms of the differential equation can also be displayed by the vector diagram shown in Fig. 3. This diagram indicates that the force amplitude, F_0 , which is measured by the force transducer, is in fact the resultant of three components. The first is an elastic component (in-phase with the displacement), the second is a viscoelastic component (90° out-of-phase with the displacement), and the third is due to the vibrating mass

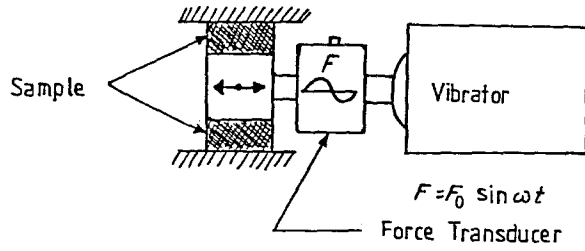

Figure 1 Mechanical arrangement of double simple shear vibrating sample.

opposing the motion (the inertia component). This can be represented by the following formula

$$F_0 = KX + C\omega X + M\omega^2 X \quad (3)$$

The shear force applied on the specimen is, in fact, the resultant of the first and the second components mentioned above

$$F_s = KX + C\omega X \quad (4)$$

We now seek to determine the shear force, F_s , and the phase shift, δ between this force and the displacement, X .

Referring to Fig. 3 and considering the triangle of the sides F_s , $M\omega^2 X$ and F_0 , we have

$$F_s^2 = F_0^2 + (M\omega^2 X)^2 - 2F_0(M\omega^2 X) \cos \theta$$

therefore

$$F_s = [F_0^2 + (M\omega^2 X)^2 + 2F_0(M\omega^2 X) \cos \phi]^{1/2}$$

or

$$F_s = \{F_0^2 + [(2\pi f)^2 MX]^2 + 2F_0(2\pi f)^2 MX \cos \phi\}^{1/2} \quad (5)$$

The complex shear modulus is defined as

$$G^* = \frac{\tau^*}{\gamma^*} \quad (6)$$

where τ^* is the total shear stress, and γ^* is the total shear strain. The shear stress is defined as

$$\tau^* = \frac{F_s}{A} \quad (7)$$

where F_s is the shear force, and A is the area under shear, where

$$A = 2ab \quad (8)$$

and

$$\gamma^* = \frac{X}{t} \quad (9)$$

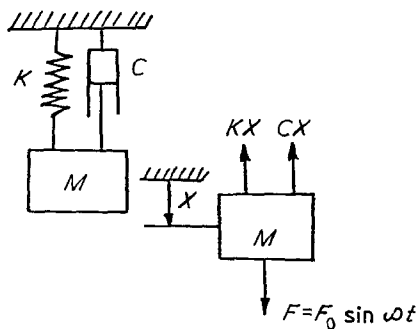

Figure 2 Viscous damping system with harmonic excitation.

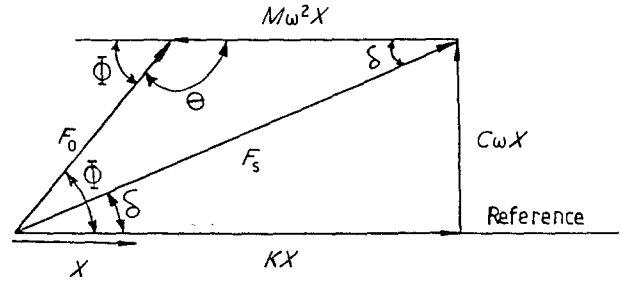

Figure 3 Vector diagram for the forces involved in the vibrating sample.

where a , b and t are the length, width and thickness of the shear specimen and X is the amplitude of vibration (the maximum deflection of the shear specimen).

From Equations 6 to 9 the complex shear modulus can be written as:

$$G^* = \frac{F_s t}{2abX}$$

Substituting Equation 5 into the above equation we find:

$$G^* = \frac{t}{2abX} \{F_0^2 + [(2\pi f)^2 MX]^2 + 2F_0(2\pi f)^2 MX \cos \phi\}^{1/2} \quad (10)$$

F_0 is obtained from the measured voltage of the input voltmeter together with the setting of the conditioning amplifier. They are both calibrated to give a resolution of 1 N V^{-1} , so the input voltmeter readings are always considered in Newtons. X is the amplitude of vibration which is obtained from the readings of the output voltmeter and from the capacitive transducer calibration constant. f is the frequency of vibration and is measured by the sine generator, ϕ is measured by the phase meter. M is the effective mass of the force transducer plus the mass of vibrating parts of the specimen.

The phase angle, δ , can be determined from the same triangle mentioned earlier in Fig. 3 as

$$\frac{F_0}{\sin \delta} = \frac{F_s}{\sin \theta} = \frac{F_s}{\sin \phi}$$

Thus

$$\sin \delta = \frac{F_0}{F_s} \sin \phi$$

or

$$\delta = \sin^{-1} \left(\frac{F_0}{F_s} \sin \phi \right) \quad (11)$$

The loss tangent, β , of the viscoelastic material, then is defined as

$$\beta = \tan \delta \quad (12)$$

The dynamic shear modulus, G' , is given by

$$G' = G^* \cos \delta \quad (13)$$

The loss shear modulus is given by

$$G'' = G^* \sin \delta \quad (14)$$

Measurements from the input voltmeter (V_{in}), the

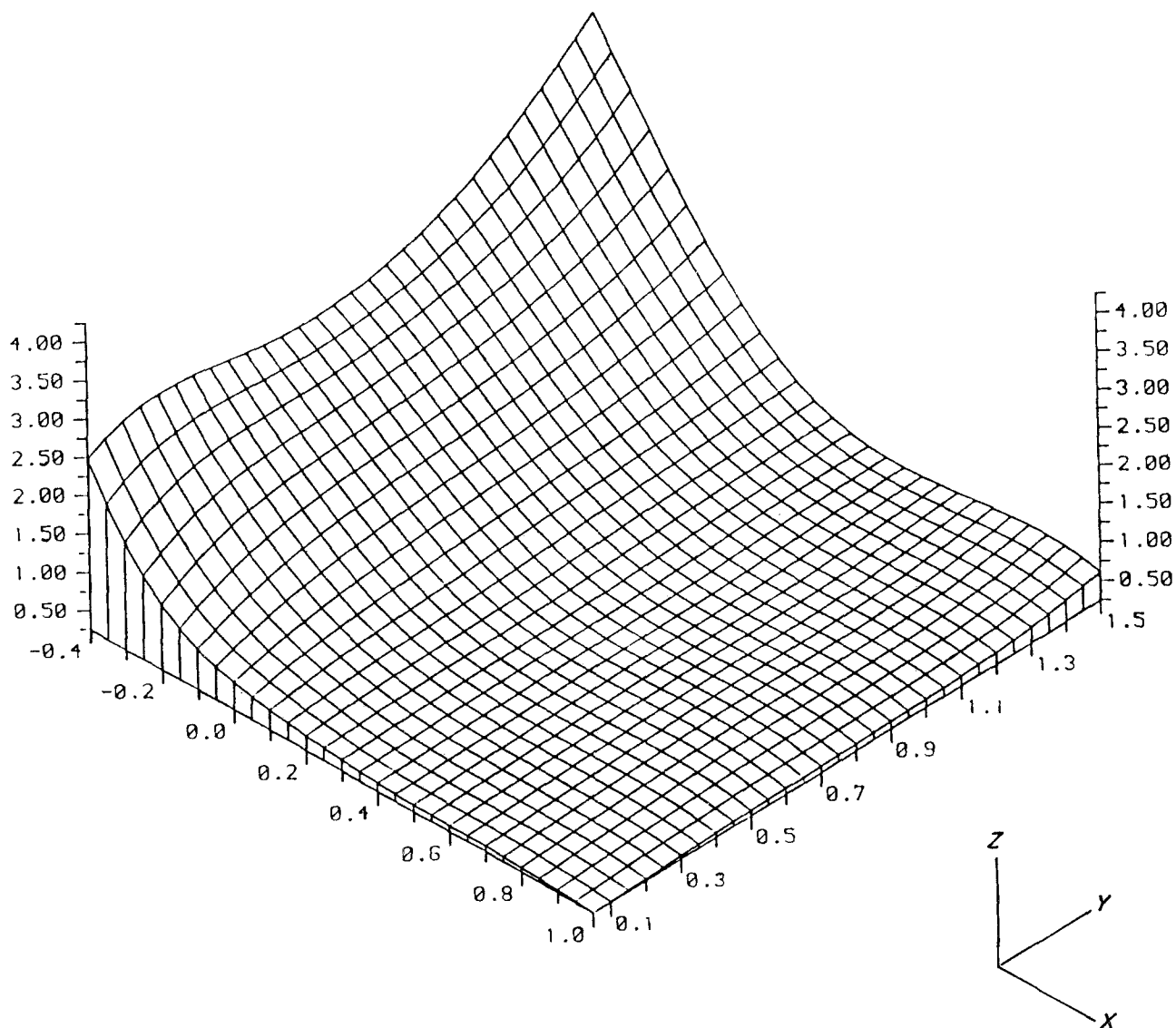

Figure 4 Dependence of complex shear modulus (z -axis, 10 N mm^{-2}) of polysulphide rubber cured for 9 months on temperature (x -axis, $10^2 \text{ }^\circ\text{C}$) and frequency (y -axis, 10^3 Hz).

output voltmeter (V_{out}) and the phase meter (ϕ) are recorded and using the calibration constants, the complex shear modulus (G^*) and its dynamic (G') and loss (G'') components are calculated from Equations 10, 13 and 14, respectively. The loss tangent is also calculated from Equation 12.

3. Statistical analysis and display of experimental results

Six samples are tested for each series of experiments. Therefore the t -test is chosen for this statistical analysis because the number of samples used for each set is less than 30 [3].

The mean values of the dynamic shear properties are graphically presented for every set of results in an isometric three-dimensional form for both materials tested. Where deemed appropriate, error bars are used to indicate the standard deviation of the results.

4. Results

The dynamic shear properties are shown in Figs 4 to 7 for polysulphide rubber and in Figs 8 to 11 for ethylene propylene rubber. A two-dimensional graph designed to show the errors in experimental values of

the complex shear modulus variations with frequency at a temperature of -40°C for polysulphide rubber is shown in Fig. 12.

Dynamic shear modulus data, measured at temperatures of -40 , -20 , 0 , 20 , 40 and 60°C and frequency range 100 to 500 Hz have been utilized to construct values of this modulus over a very wide range of frequency using the principle of reduced variables. The dynamic shear modulus (G'_r) reduced to 0°C is plotted against frequency. The experimental values of dynamic shear modulus (G'_m), measured at 0°C and in the frequency range of 50 to 1500 Hz, are also plotted on the same graph. This is shown for polysulphide rubber in Fig. 13 and for ethylene propylene rubber in Fig. 14.

5. Discussion

5.1. Validity of mechanical property results

A similarity in the change of complex shear modulus (G^*) and its dynamic component (G') with frequency and temperature is clear. This can be seen by comparing Figs 4 and 8 with Figs 5 and 9, respectively. The trend is as expected; an increase with frequency and a decrease with temperature. The difference between G^*

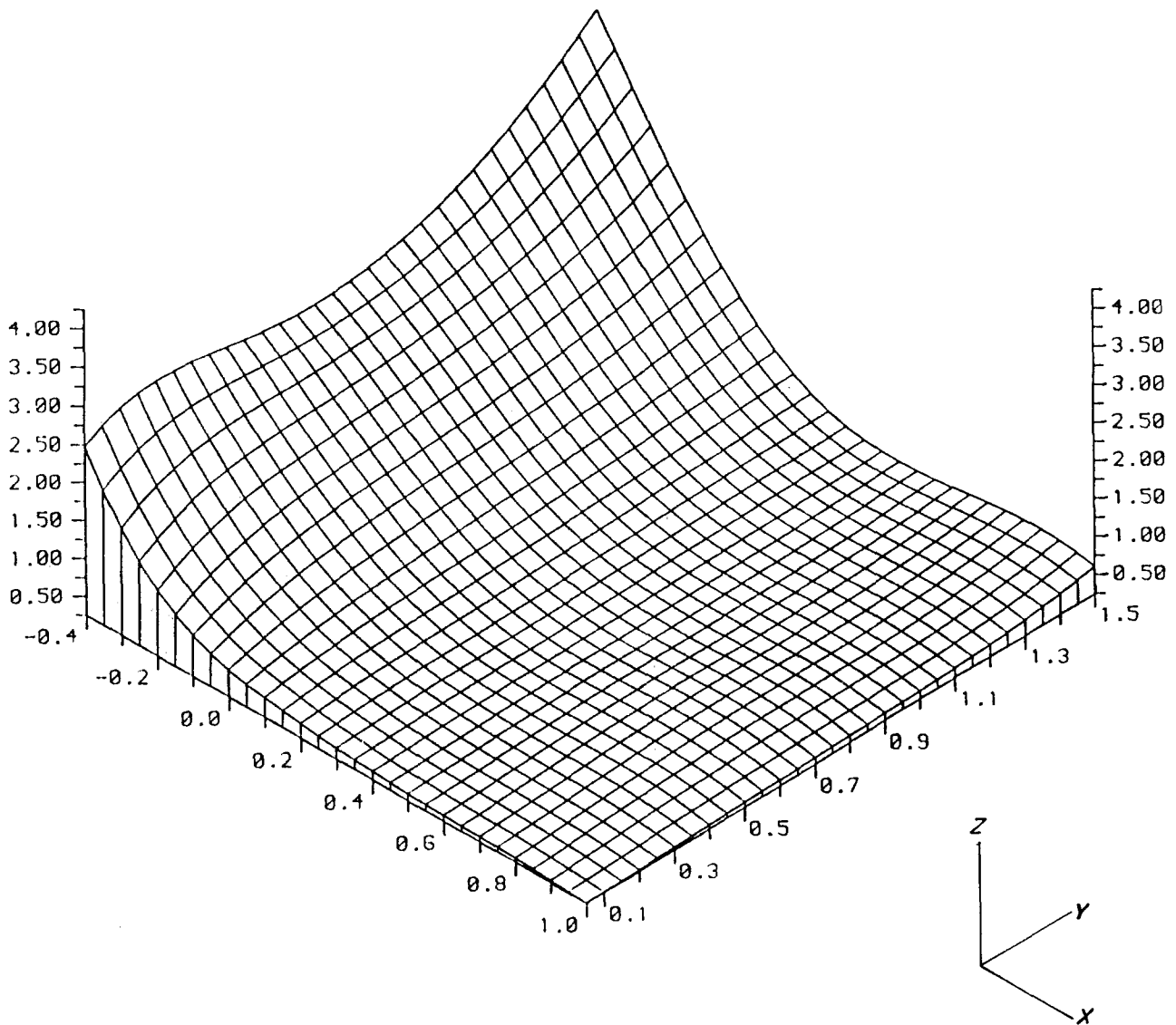

Figure 5 Dependence of dynamic shear modulus (z -axis) of polysulphide rubber cured for 9 months on temperature (x -axis) and frequency (y -axis). For units, see Fig. 4.

and G' is small as the range of temperature is in the rubbery zone and relatively little damping would be expected. Some fluctuation in G^* and G' is observed as the temperature decreases towards -40°C . This is perhaps due to both elastomers approaching a transition from a rubber-like to a glass-like condition, especially at temperatures of -40°C . (See, for example, Fig. 7 where a sign of a peak in the loss tangent is observed at -40°C and around 1150 Hz.) A step increase in G' , which presumably reflects a peak in $\tan \delta$, is also observed at about 1200 Hz in Fig. 11.

Fig. 12 is introduced in a two-dimensional form to show the fluctuation in the values of G' and to show that the error bars are noticeably high at -40°C . This indicates the difficulty of measuring dynamic properties at temperatures approaching the glass transition (T_g) [4]. The fact that measurements are difficult in the transition region is due to the short time available for molecules to adjust themselves after distortion because their thermal motions become sluggish in this temperature region [5, 6]. The transition region for both elastomers considered in this work is in the -40°C range [7-10].

A close look at Fig. 12 indicates a drop of modulus value between 250 and 300 Hz for polysulphide rubber. This may be caused by ice formation on the specimens prior to testing. A break away of this ice may perhaps occur causing the sharp drop in modulus. This is noticeable also in the case of the ethylene propylene rubber at about 800 Hz. The fluctuation in the latter rubber is more pronounced as can be seen in Fig. 9. In the case of polysulphide rubber the rubber is self adhered to the driven member and specimen holder as shown in Fig. 1. In the case of the ethylene propylene rubber, the specimens are adhered with Loctite Super Glue. The nature of this joint may have caused the fluctuation in the modulus values.

The experimental results for both types of rubber (G'_m), measured within a temperature range -40 to 100°C and frequency range 50 to 1500 Hz, show reasonable correlation with the reduced values of dynamic shear modulus (G'_r) (Figs 13 and 14).

5.2. Molecular physics of elastomers

The dynamic shear modulus, G' , varies between a lower value given by G_c in the rubbery region (low frequency, high temperature) and a higher value,

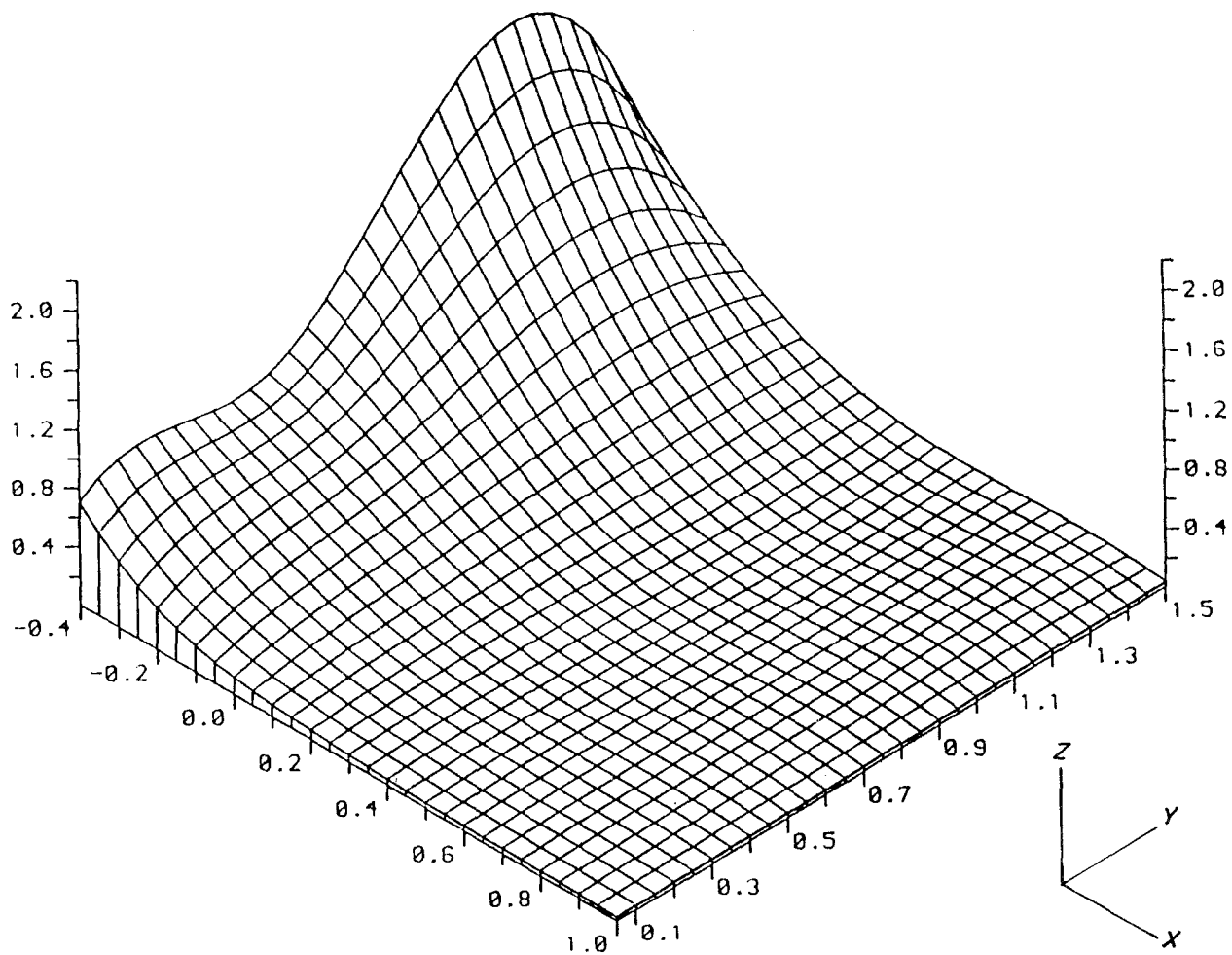

Figure 6 Dependence of loss shear modulus (z-axis) of polysulphide rubber cured for 9 months on temperature (x-axis) and frequency (y-axis). For units, see Fig. 4.

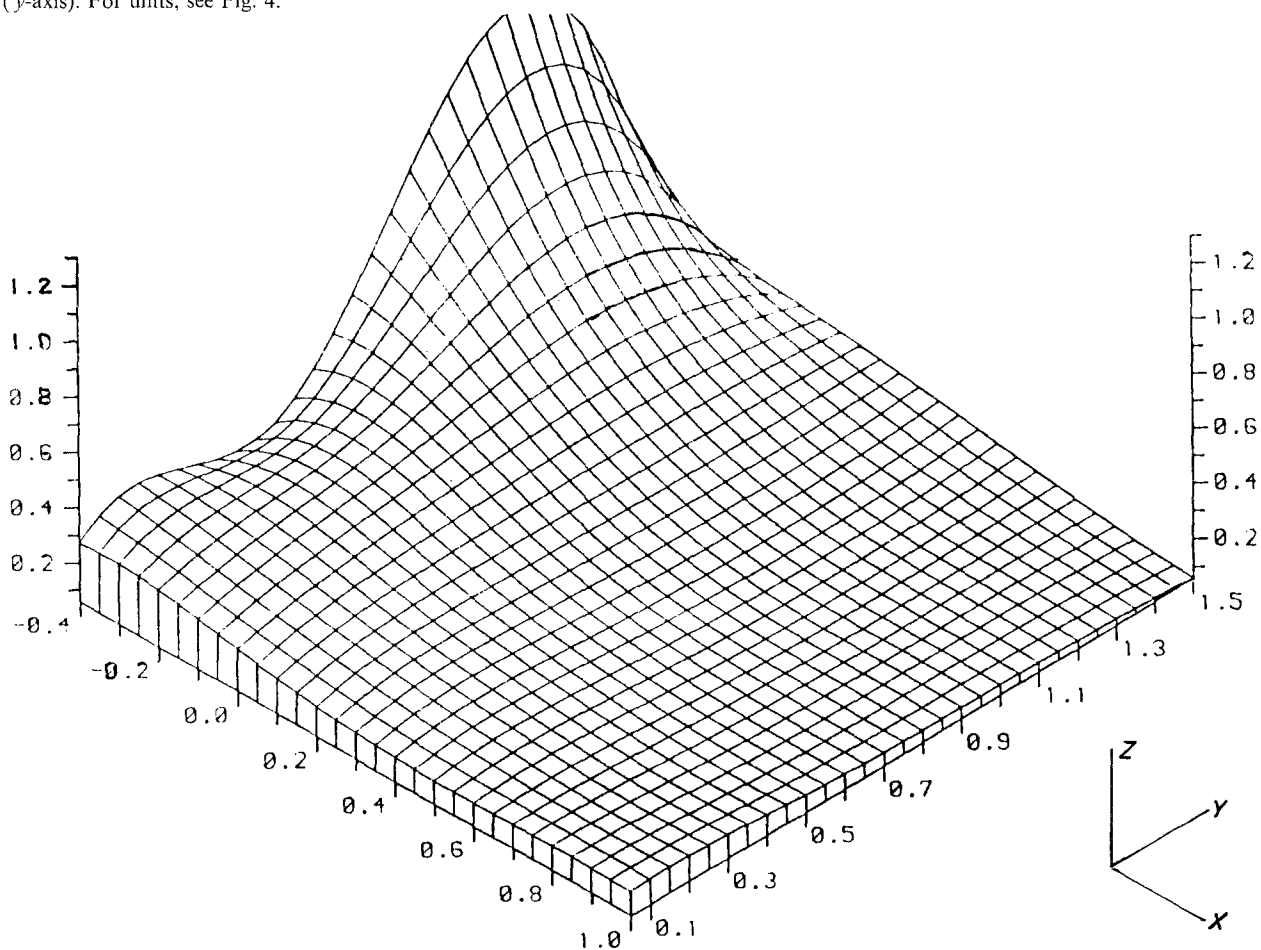

Figure 7 Dependence of loss tangent (z-axis) of polysulphide rubber cured for 9 months on temperature (x-axis, 10^2 °C) and frequency (y-axis, 10^3 Hz).

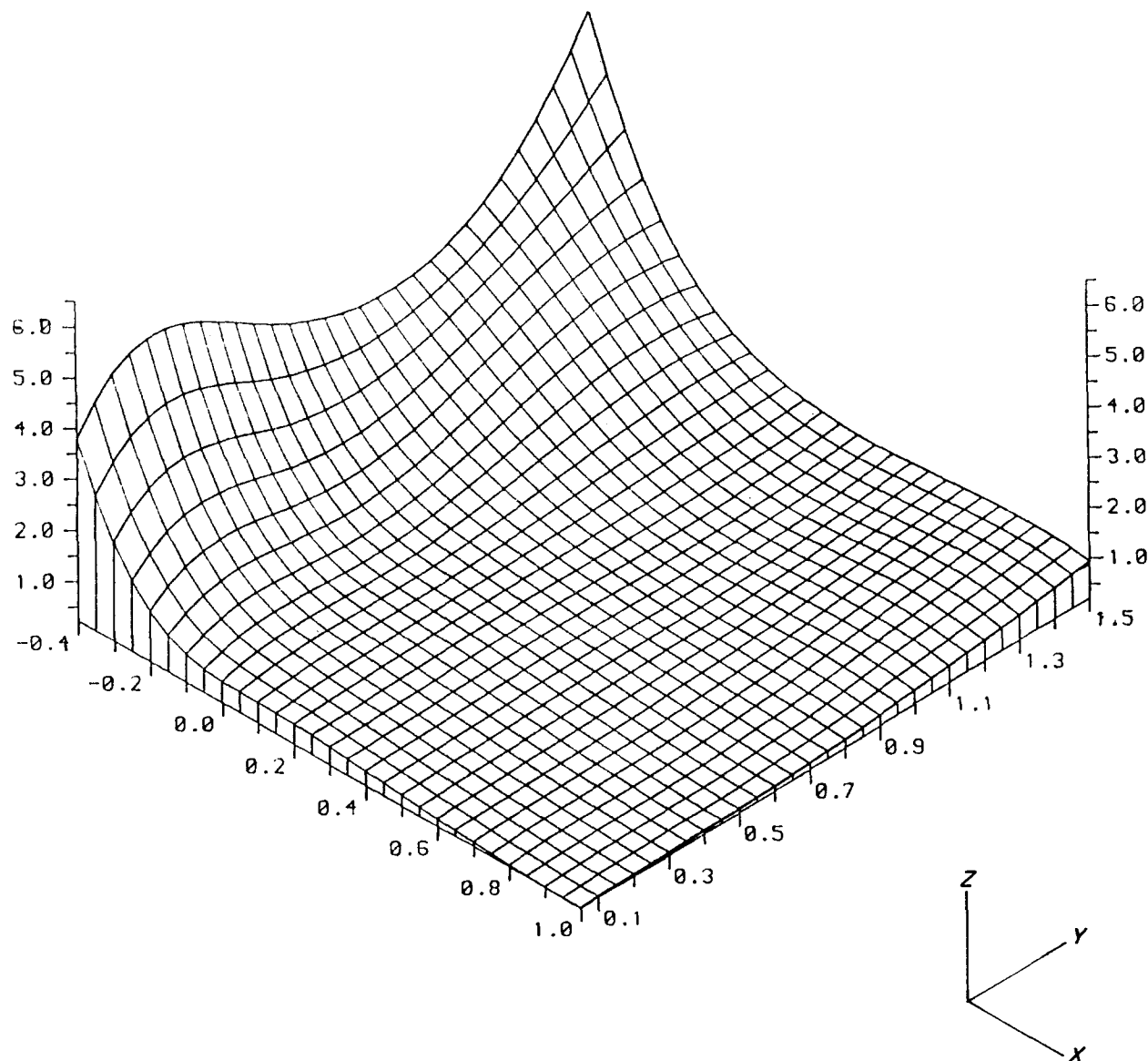

Figure 8 Dependence of complex shear modulus (z -axis) of ethylene propylene rubber on temperature (x -axis) and frequency (y -axis). For units, see Fig. 4.

roughly $2G_c$, when the material is glass-like (high frequency, low temperature). The dynamic mechanical properties of polymers are dependent on their physical chemistry. Mooney [in 4, 11] has evaluated a theory of cross-linked polymer networks which can be used to quantify G^* , G' and G'' .

In Mooney's theory

$$G_c = g\nu RT$$

where ν is the moles of network strands per cm^3 or the density of strands that are terminated at both ends by chemical cross-links; g is the ratio of the mean square end-to-end distance of a strand to the mean square end-to-end distance which strands of the same length would assume if not constrained by cross-links.

Our measurements made at 50 Hz with ethylene propylene rubber are sufficiently close to the lower end of the frequency range where rubbery behaviour is expected to allow direct substituting of the measured G' values for G_c in the above equation. Thus, it is possible to estimate ν from the mechanical properties. This can also be done by making assumptions about the polymer chemistry.

5.2.1. Polymer chemistry approach

The weight average molecular weight in EPDM elastomers may range between 1.6×10^5 and 3×10^6 [7]. The density of the ethylene propylene rubber used is 0.85 g cm^{-3} . The concentration of the third monomer in EPDM compounds is between 1 and 2 mol % [7]. The chemical cross-links take place with the third monomer. Let us define the piece of polymer in a backbone molecular chain which contains no cross-links as a strand. We assume that the third monomer or the cross-linking monomer is spread evenly along the polymer chain. Hence the number of cross-linking monomer units per polymer molecule is equal to the number of strands per molecule (see Fig. 15).

Assume the molecular structure of our rubber is a regular alternating ethylene (C_2H_4)/propylene (C_3H_6), i.e. 50/50 equimolar percentage with 2 mol % 1,4 hexadiene (C_7H_{10}), and the average molecular weight is 3×10^6 [7].

The monomer molecular weight of ethylene propylene is 60. The monomer weight of 100 monomer units of ethylene propylene will be $60 \times 100 = 6000$. If we assume 2% cross-linking third polymer, the

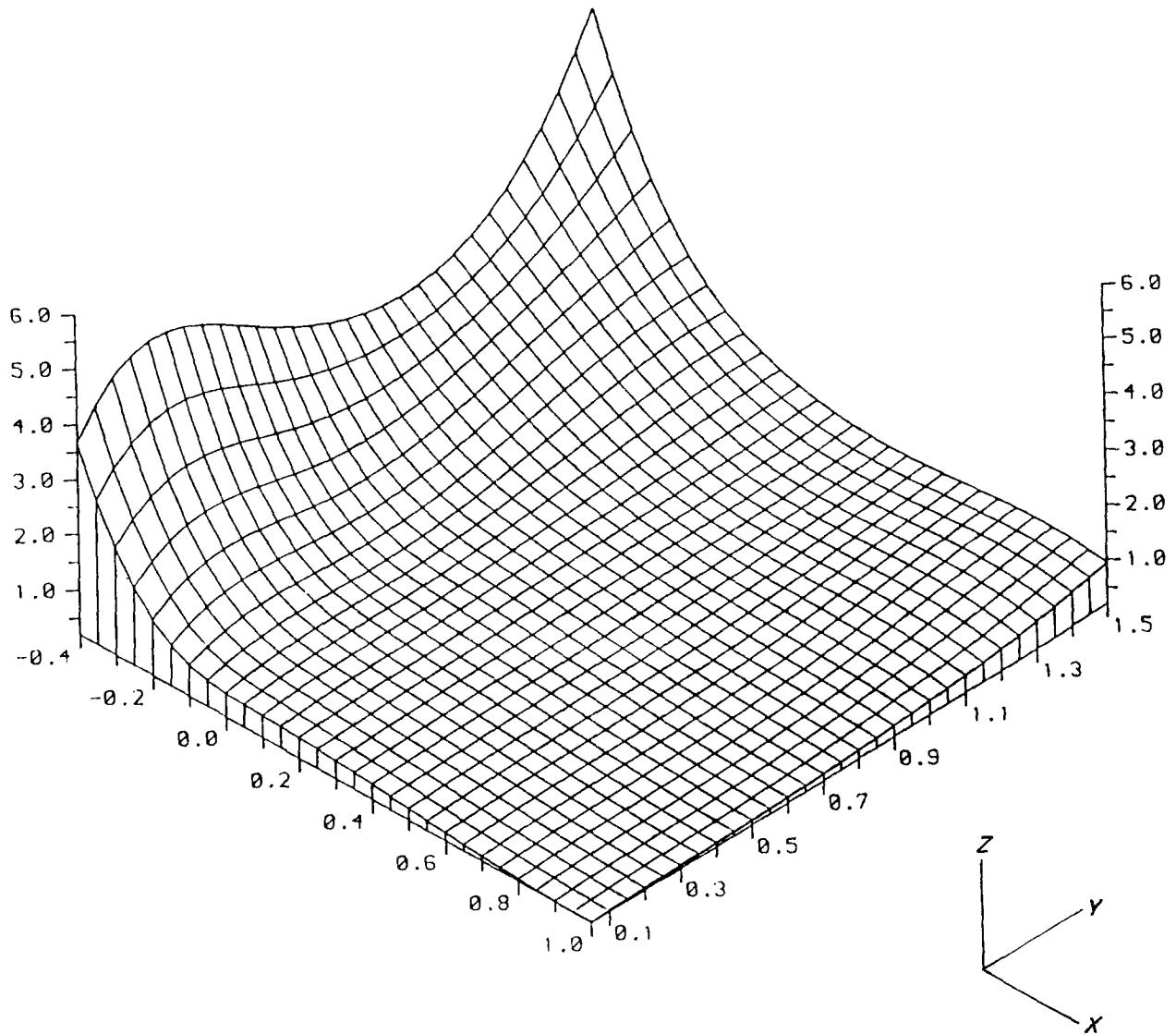

Figure 9 Dependence of dynamic shear modulus (z -axis) of ethylene propylene rubber on temperature (x -axis) and frequency (y -axis). For units, see Fig. 4.

weight of a strand which is terminated at both ends by chemical cross-links will be $6000/2 = 3000$.

The number of strands or the number of cross-links in one molecule will be

$$\frac{3 \times 10^6}{3000} = 1000 \text{ strands/molecule}$$

The number of molecules per unit volume or the molecular density of the rubber and the strand density can be estimated as follows.

In 3×10^6 g rubber we have 6×10^{23} molecules.

In 0.85 g cm^{-3} we will have $6 \times 10^{23} \times 0.85 / 3 \times 10^6 = 1.7 \times 10^{17}$ molecules/cm³.

Thus the number of strands per unit volume or the strand density, ν , will be $1000 \times 1.7 \times 10^{17} = 1.7 \times 10^{20}$ strands/cm³.

This is represented physically by the situation in Fig. 15a.

5.2.2. Mechanical properties approach

The density of strands can be estimated by the following equation

$$\nu = \frac{G_c \times N_0}{RT}$$

where G_c is the equilibrium dynamic shear modulus

$\approx 3.041 \text{ N mm}^{-2}$ (G' from EP rubber at low frequency in this work), N_0 is Avogadro's number = 6×10^{23} atoms mol⁻¹, R is the gas constant = 8.314 J K^{-1} mol⁻¹, T is the temperature = 293 K . Substituting these values in the above equation gives

$$\begin{aligned} \nu &= \frac{3.041 \times 10^6 \times 6 \times 10^{23}}{8.314 \times 293 \times 10^6} \\ &= 7.5 \times 10^{20} \text{ strands/cm}^3 \end{aligned}$$

This figure includes the chemical cross-links and possible entanglement. Compare 7.5×10^{20} with 1.7×10^{20} . The difference between these figures may be attributed to the possibility of coupling entanglement (case b in Fig. 15) and to the approximations initially assumed in this mechanical property-based estimation.

It must be added that the Mooney theory does not account for the presence of filler in the rubber compound. In the EP rubber there is 20 p.h.r. of FEF black, which may also have contributed to the difference in this comparison.

5.2.3. Summary

The number of strands in a molecule can therefore be

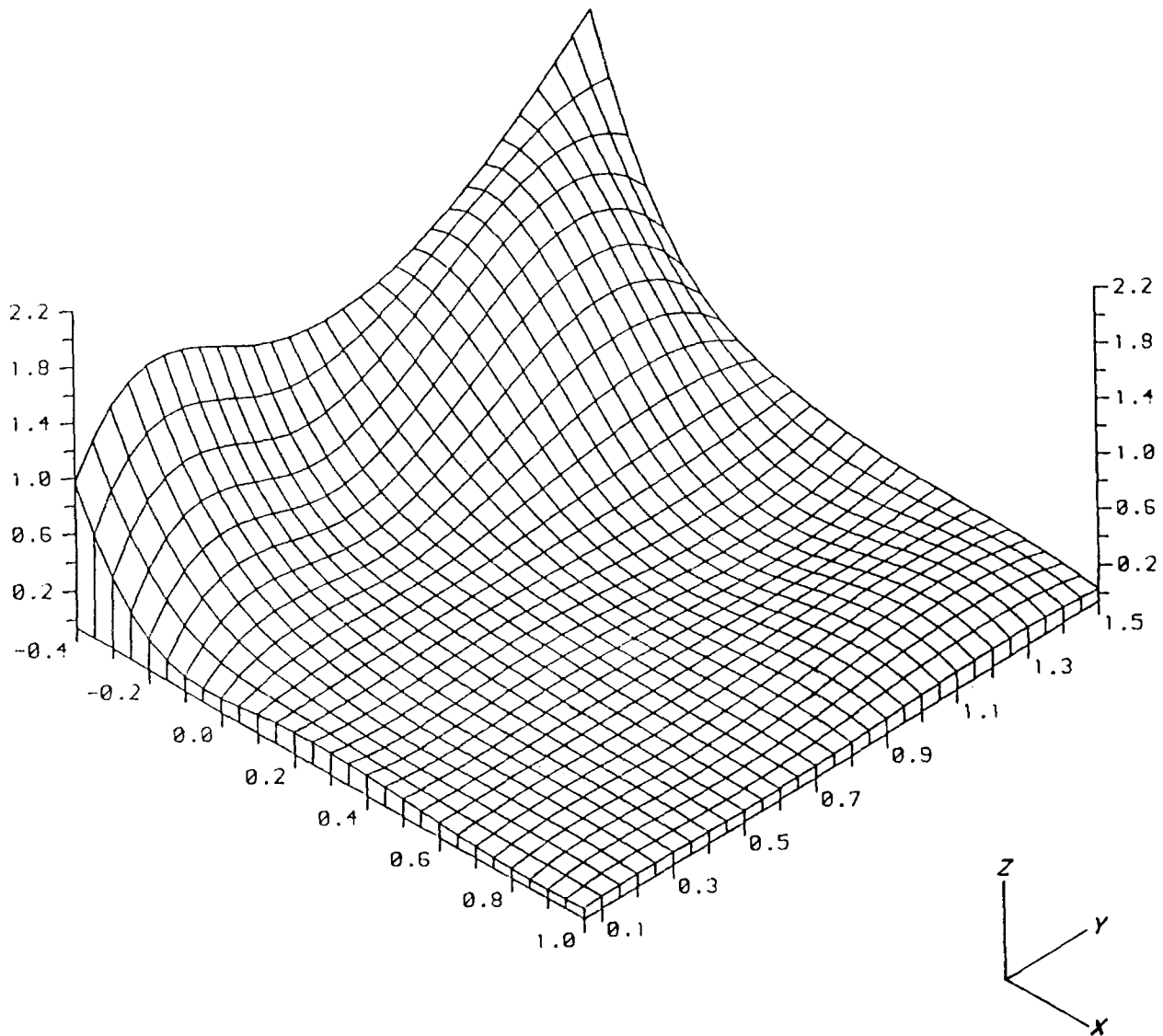

Figure 10 Dependence of loss shear modulus (z -axis) of ethylene propylene rubber on temperature (x -axis) and frequency (y -axis). For units, see Fig. 4.

estimated. This is

$$\frac{\text{number of strands/cm}^3}{\text{number of molecules/cm}^3} = \frac{7.5 \times 10^{20}}{1.7 \times 10^{17}} \approx 4412 \text{ strands/molecule}$$

which includes chemical cross-links and coupling entanglement (case b in Fig. 15), compared with the polymer chemistry approach value of 1000 strands/molecule which are terminated at both ends by chemical cross-links only (case a in Fig. 15).

Another way of expressing this in the context of the G_e equation is to say that ν is 1.7×10^{20} strands cm^{-3} and that

$$g = \left(\frac{1/\text{No. of strands/molecule without cross-linking}}{1/\text{No. of strands/molecule with cross-linking}} \right)^2 = \left(\frac{4412}{1000} \right)^2 = 19.5$$

5.3. Heating effects

Heat builds up inside the specimen as a result of the dissipation of energy due to the phase difference between strain and stress in the vibrating rubber specimen. This dissipated energy is a part of the energy input into the rubber specimen, which is not returned during the recovery part of the vibrating

cycle. From this phase difference, a hysteresis loop can be produced, when the oscillating stress and strain signals are displayed on an oscilloscope. If the stress and strain cycles are sinusoidal, this loop is an ellipse, which is well known as the "Lissajou Figure". The energy dissipated as heat per cycle per unit volume is represented by the enclosed area of the ellipse and it may be defined by Q [5, 6].

$$Q = \pi \tau^* \gamma^* \sin \delta \quad (20)$$

where τ^* is the amplitude of the total stress cycle, γ^* is the amplitude of the total strain cycle, and δ the phase shift between stress and strain cycles.

In a simple rubber-metal bonded specimen subjected to a sinusoidal shear stress, the maximum temperature rise (ΔT) is expressed as [5, 12]

$$\Delta T = \frac{q t_1^2}{8 k_1} + \frac{g t_1^2}{2C} \quad (21)$$

where t_1 is the thickness of the rubber specimen, k_1 the

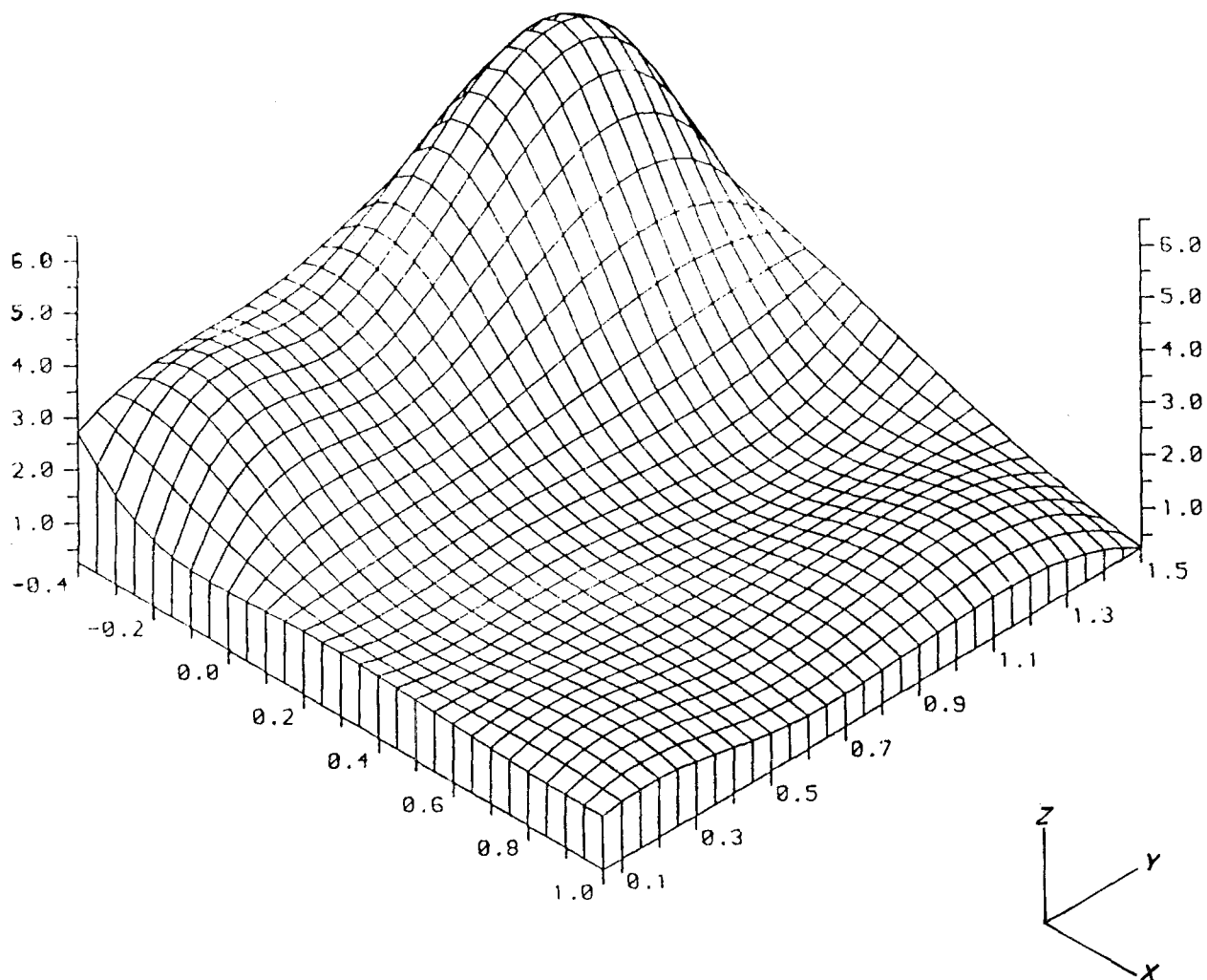

Figure 11 Dependence of loss tangent (z -axis, $\times 10^{-1}$) of ethylene propylene rubber on temperature (x -axis, 10^2 °C) and frequency (y -axis, 10^3 Hz).

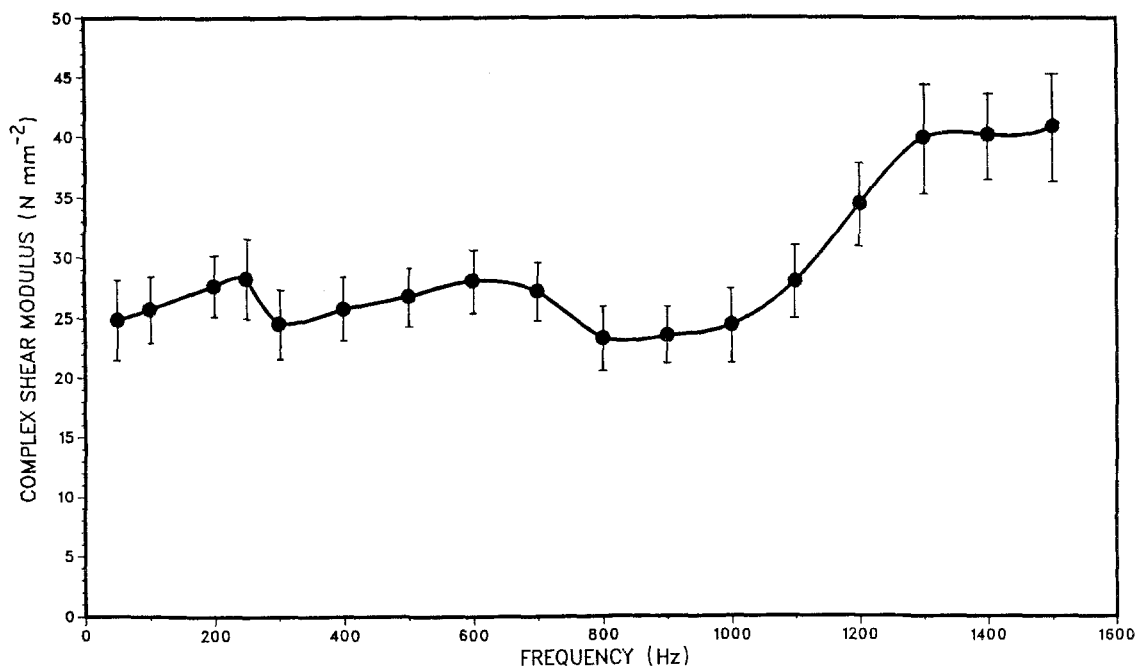

Figure 12 Complex shear modulus plotted against frequency for polysulphide rubber at -40°C .

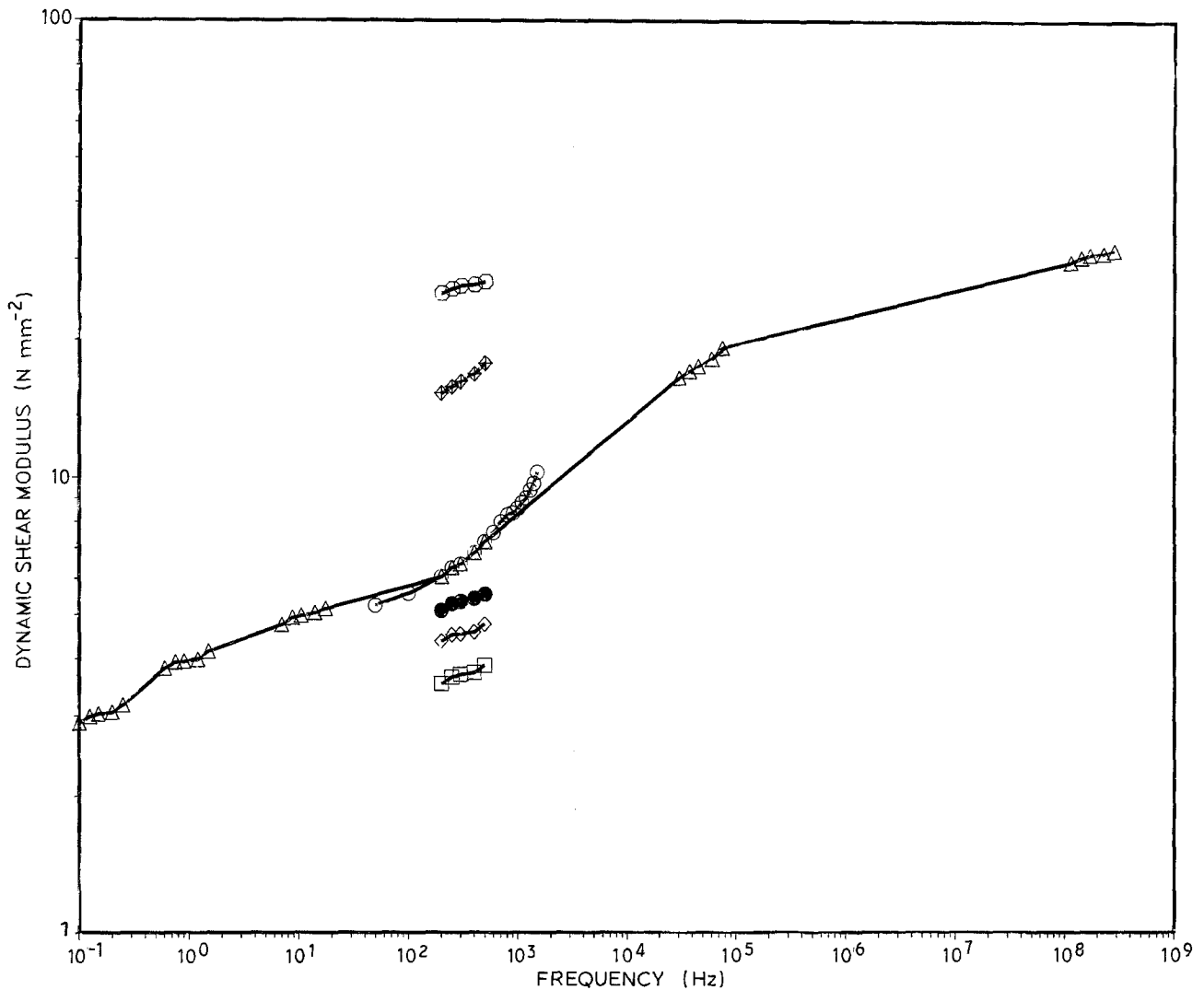

Figure 13 The dynamic shear modulus plotted against frequency for polysulphide rubber constructed from data obtained within a limited frequency range and at different temperatures, the reference temperature = 0°C. Values of this modulus, measured at 0°C, are also shown, $T = (\circ) -40, (\oplus) -20, (\bullet) 20, (\diamond) 40, (\square) 60^\circ\text{C}$. (Δ) G' reduced, (\circ) G' measured.

thermal conductivity of the rubber, q the heat generated per unit volume per second, obtained from Q in Equation 20, C is a function of the boundary condition given by

$$\frac{1}{C} = \frac{t_2}{k_2 h} \quad (22)$$

where t_2 is the thickness of the metal strip bonded to the rubber, k_2 the thermal conductivity of the metal, and h the heat transfer coefficient for metal/air.

Approximate estimation is made for the rise in temperature due to the dissipation of energy caused by the vibration of the test specimens. The estimation is made for both test materials at fixed conditions of temperature (20°C) and frequency (1000 Hz). The estimated values of the rise in temperature (ΔT) are found as below:

- $\Delta T \approx 11.4^\circ\text{C}$ for polysulphide rubber cured for 1 wk
- 8.5°C for polysulphide rubber cured for 9 months
- 31.2°C for ethylene propylene rubber

The heat build-up, as a result of the lost energy in the rubber specimens subjected to dynamic loading, is affected by a fraction of the lost energy which can be transferred from the rubber specimens, although the

rubber is a poor conductive material. Heat-transfer problems are complex and depend on the geometry of the rubber specimens [13, 14]. That is why in the above estimation, ΔT for ethylene propylene rubber is higher than that for polysulphide rubber, because the thickness of the first material specimens is higher than that of the second material. The adoption of brass as the metallic material attached to the rubber specimens is because brass has a considerable thermal capacity and it is a good heat conductor. This assists in extracting part of the heat dissipated in the rubber specimens through the considerable surface area of the attached components.

Several practical attempts were made to detect the rise in temperature due to vibration. This rise was detected by inserting a very thin thermocouple probe into the test specimen. The probe was carefully located as close to the shear surface as possible. Under the same conditions at which the above data were obtained, the rise in temperature caused by vibrating the specimen was recorded. It was found that by increasing the operating frequency from 100 to 1000 Hz, the temperature of the rubber specimens rose to 3 to 4°C approximately above the ambient temperature. Similar observations were reported by

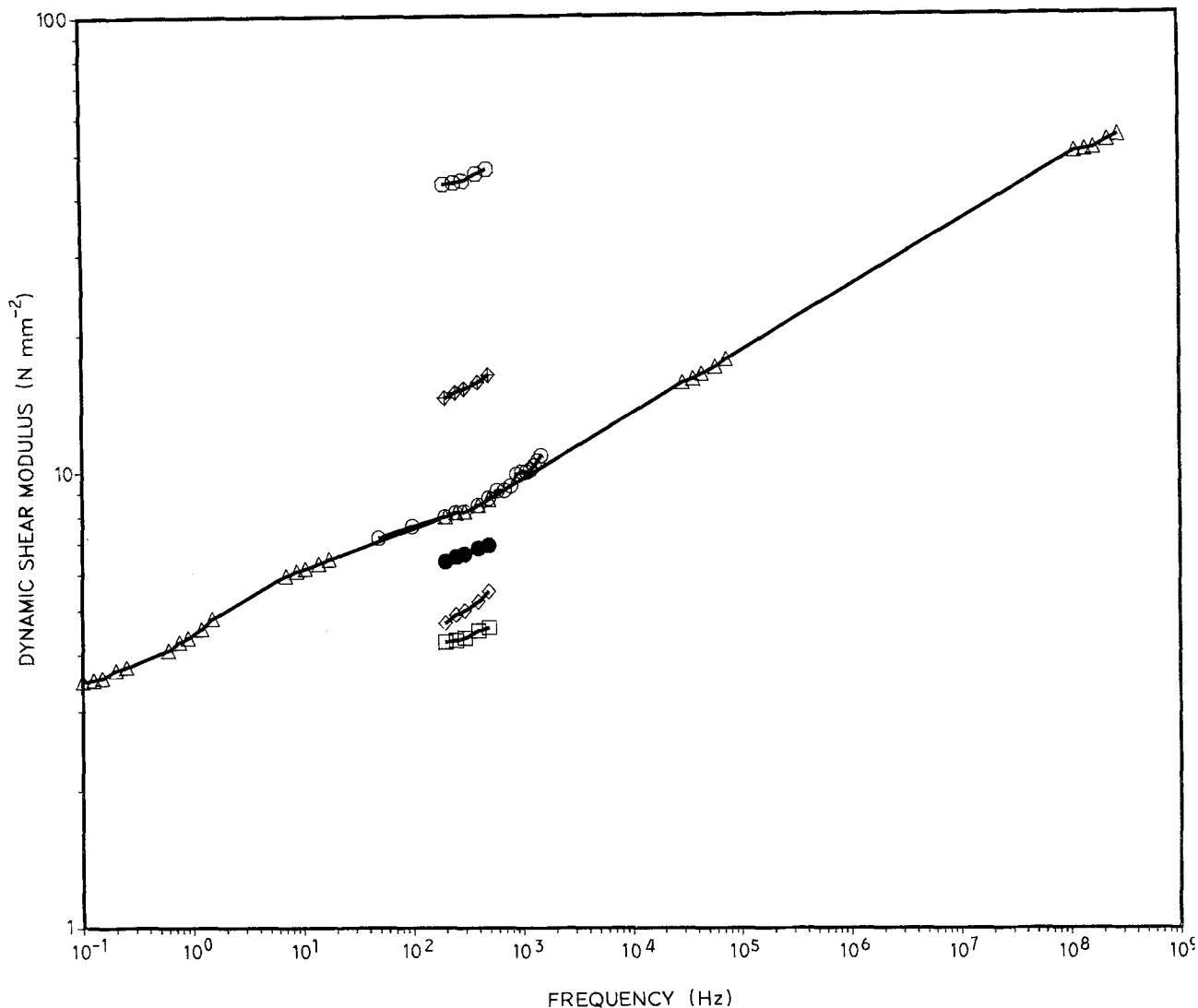

Figure 14 Dynamic shear modulus plotted against frequency for ethylene propylene rubber constructed from data obtained within a limited frequency range and at different temperatures, reference temperature 0°C. Values of this modulus, measured at 0°C, are also shown. For key, see Fig. 13.

NASA [15], under similar conditions, except that the rubbers used were urethane and neoprene and the method of property measurement was the forced vibration resonant method. It can be seen that the rise in temperature detected by experiment (3 to 4°C) is less than the calculated values mentioned above: compare 3 to 4°C with 11.4, 8.5 and 31.2°C. This difference is due to the fact that the probe could not be located exactly at the shear surface where the maximum deformation of the rubber specimens occurs, as it is well known that the heat generation is not only related to the frequency of vibration, but also to the amplitude of deformation, see Equation 20.

5.4. Effects of curing time and strain amplitude

The polysulphide rubber cured for 1 week and for 9 months was tested to show the effect of curing time on the dynamic shear properties of this material. It is worth noting that the effect of curing time is almost negligible. It was found that the effect of strain amplitude on these properties was insignificant over most of the operating frequency and temperature ranges. This is in agreement with earlier works [16, 17].

6. Conclusions

1. The method of measurement used in this work proved to be effective in providing direct measurement of dynamic shear properties over a wide range of temperature (-40 to 100°C) and frequency 50 to 1500 Hz.

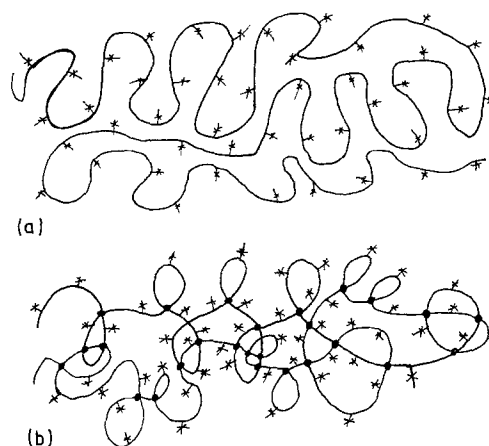

Figure 15 A single molecule of ethylene propylene rubber with (a) strands terminated at chemical cross-linking only occurring at the presence of the third monomer, (x), (b) strands terminated at chemical cross-linking and coupling entanglement, (●).

2. Both ethylene propylene (EP) and polysulphide rubber (PS) materials possess reasonable damping in the transition regions at -40°C and 1 kHz or at 20°C and 1150 Hz.

3. Reasonable correlation exists between the directly measured modulus and that superpositioned using the method of reduced variables.

4. The Mooney molecular theory of cross-linked polymer networks can be used in conjunction with the observed modulus, especially at low frequencies, to define the degree of cross-linking and entanglement within the EP elastomer.

Acknowledgements

The authors thank Professor I. A. Menzies for provision of laboratory facilities and Mr P. G. Howgate and Mr P. K. Freakley for helpful discussions.

References

1. M. N. DARROUJ, PhD thesis, Loughborough University of Technology (1987).
2. M. N. DARROUJ and R. G. FAULKNER, *J. Phys. E: Sci. Instrum.* **22** (1989) 218.
3. T. CASS, "Statistical Methods in Measurement 1" (Cassell, London, 1978).
4. J. D. FERRY, "Viscoelastic Properties of Polymers" (Wiley, New York, 1970).

5. P. K. FREAKLEY and A. R. PAYNE, "Theory and Practice of Engineering with Rubber" (Applied Science, London, 1978).
6. A. B. DAVEY and A. R. PAYNE, "Rubber in Engineering Practice" (Maclaren, London, 1964).
7. C. A. VAN GUNST, "Rubber Technology", DSM Research and Patents, Holland, personal communication.
8. P. G. HOWGATE, personal communication.
9. LP Liquid Polysulphide Polymer Bulletin, Morton Thiokol Inc. 1981.
10. B. PETERSON, "Factors affecting the water resistance of LP based sealants" (Thiokol, Warwick, 1983).
11. M. MOONEY, *J. Polymer Sci.* **34** (1959) 599.
12. E. F. GOBELL, "Rubber Spring Design", English Translation (Butterworth, London, 1974).
13. W. H. McADAMS, "Heat Transmission", 3rd Ed (McGraw-Hill, London, 1954).
14. L. C. THOMAS, "Fundamentals of Heat Transfer" (Prentice-Hall, New Jersey, 1980).
15. NASA-CR-120965 (1972), NASA-CR-134704 (1974).
16. W. P. FLETCHER and A. N. GENT, *Brit. J. Appl. Phys.* **8** (1957) 194.
17. G. E. WARNAKA and H. T. MILLER, *Rubber Chem. Technol.* **39** (1966) 1421.

*Received 3 October 1988
and accepted 28 February 1989*